



PHILADELPHIA 2012
HIGHSPEED
8th World Congress on High Speed Rail

Cost effective duplex tunnels and bridges

Per, CORSHAMMAR

Manager Railway Engineering, Ramböll, Sweden

11 July 2012, Session: Infrastructure1

Content

- **Definition of tunnel types**
 - Single pipe tunnel
 - Double pipe tunnel
 - Single pipe wide body
 - Duplex tunnel and bridge
- **Tunneling diameter 7 – 15 meters**
- **Cost effective tunnels and bridges**
- **Conclusion of urban tunnel planning**

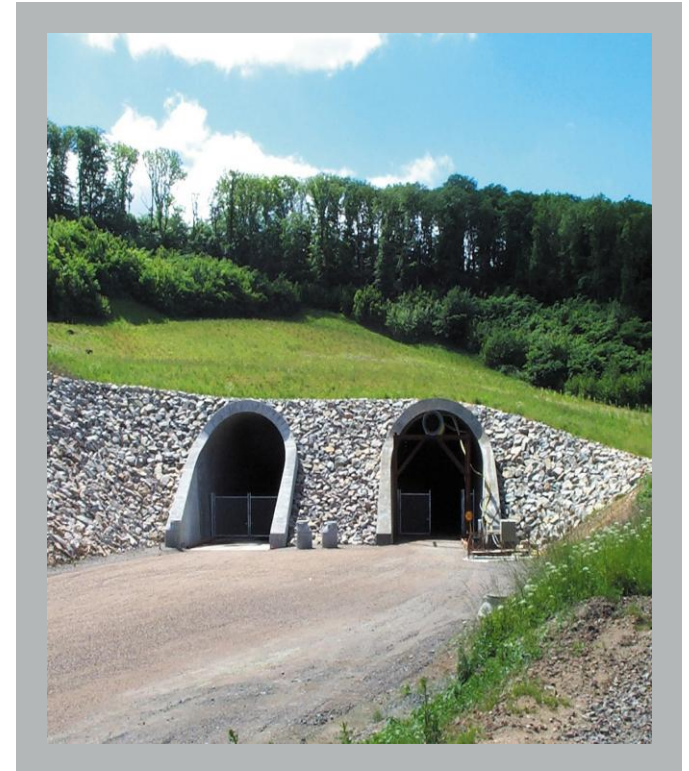

Cost effective duplex tunnels and bridges

■ HSL Copenhagen - Oslo

- Oslo S – Ski Tunnel, 19 km
- Nygårds- and Kattleberg Tunnel 4.8 km
- The Gotenburg City Line Tunnel 8 km
- The Hallandsås Tunnel 8 km
- The Malmö City Tunnel 6 km
- The Öresund Bridge 12 km
- The Copenhagen City Tunnel 10 km
- Helsingborg – Helsingör Tunnel 5 km



Cost effective duplex tunnels and bridges

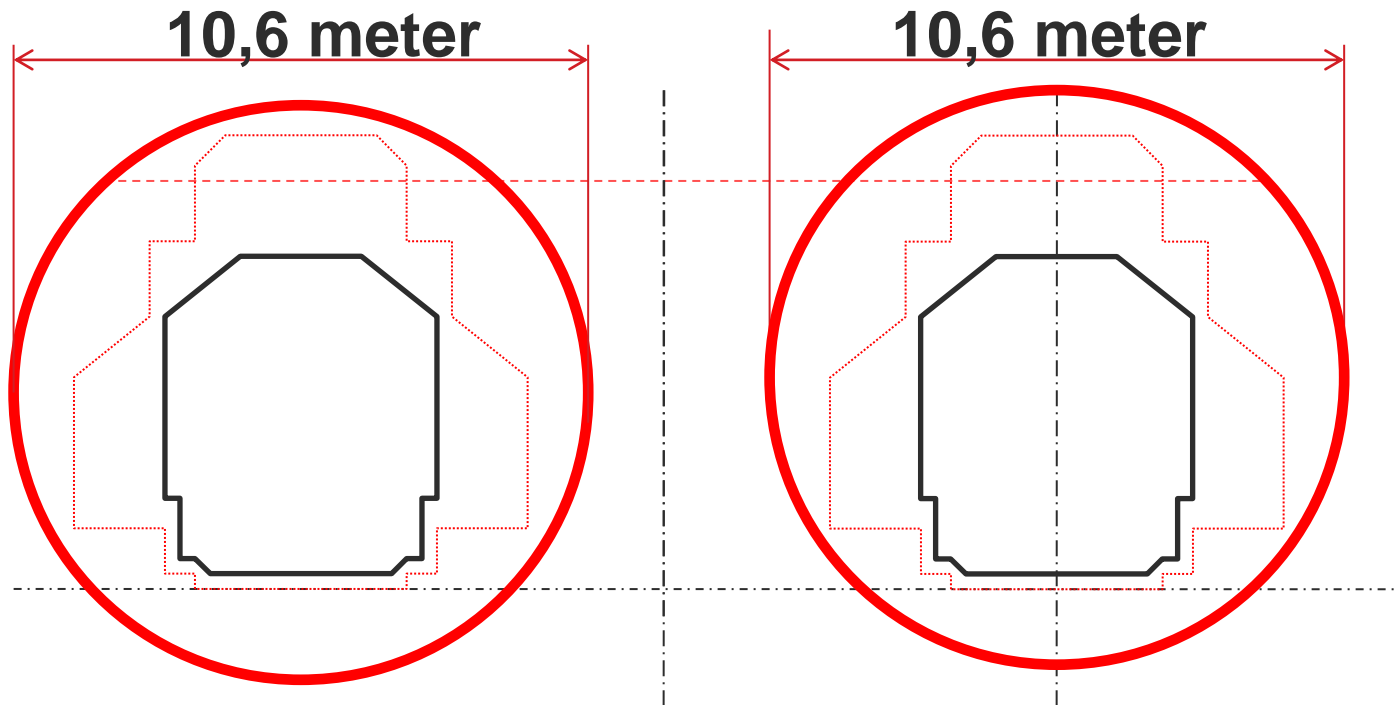

Double pipe tunnel
The Hallandsås Tunnel

Cost effective duplex tunnels and bridges

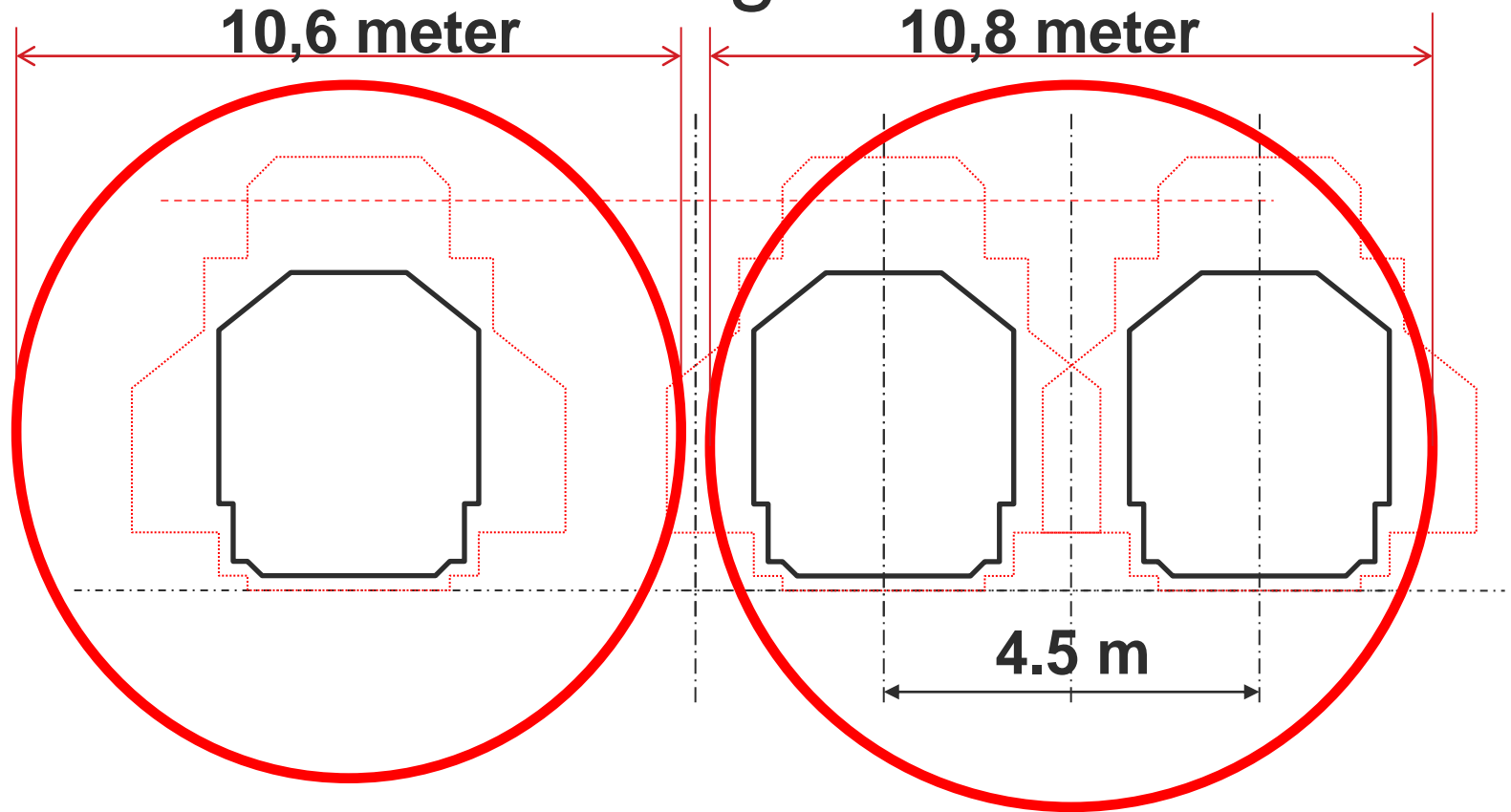

Double pipe tunnel
The Hallandsås Tunnel

Singel pipe wide body tunnel
Nygårds Tunnel

Japanese HSL single pipe wide body

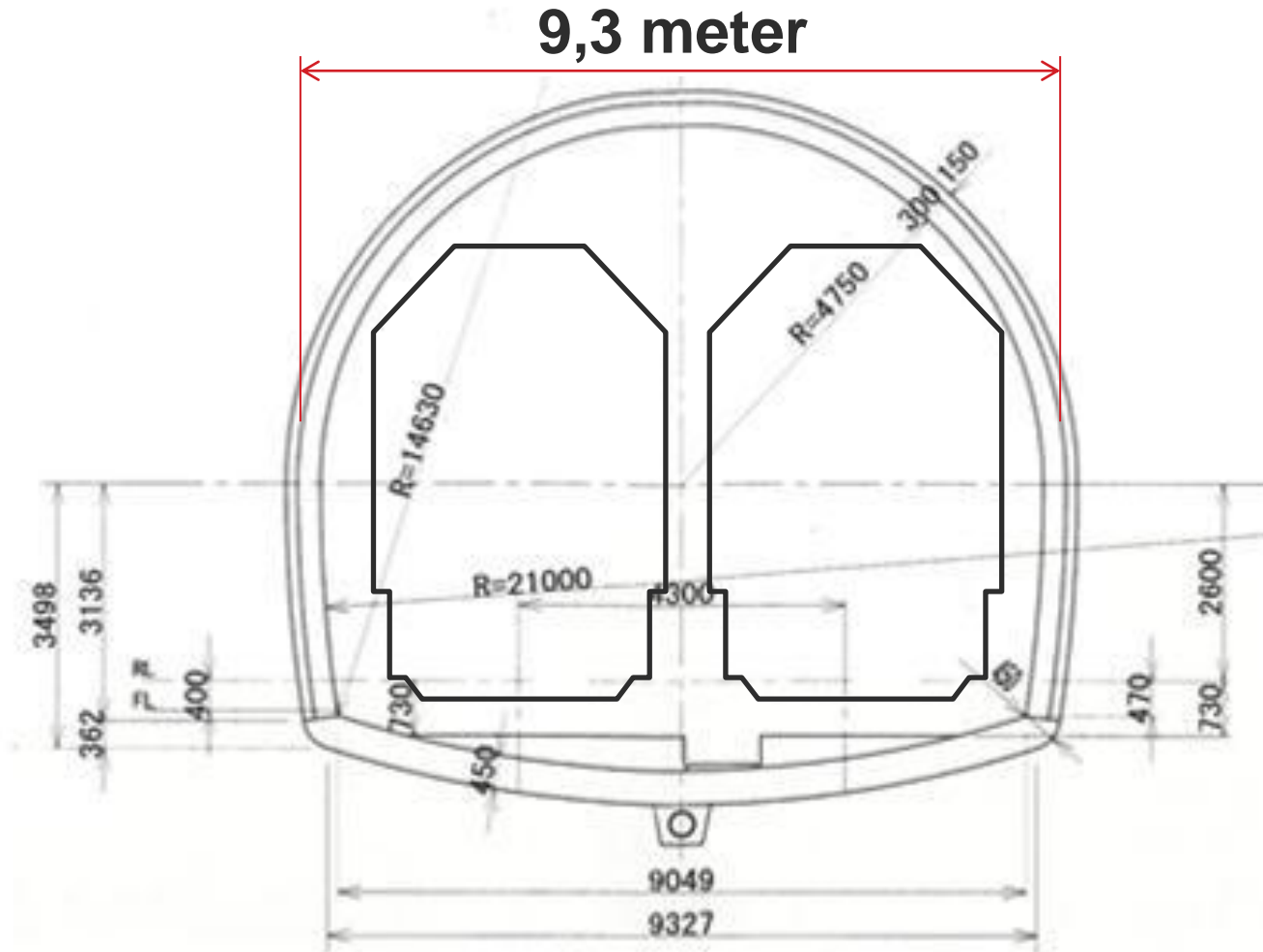

Cost effective duplex tunnels and bridges

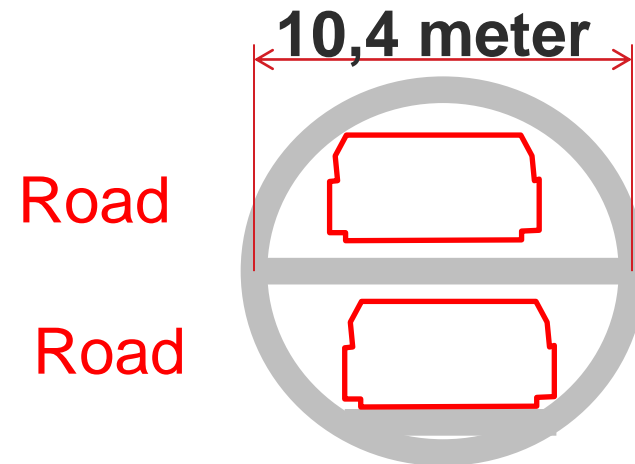
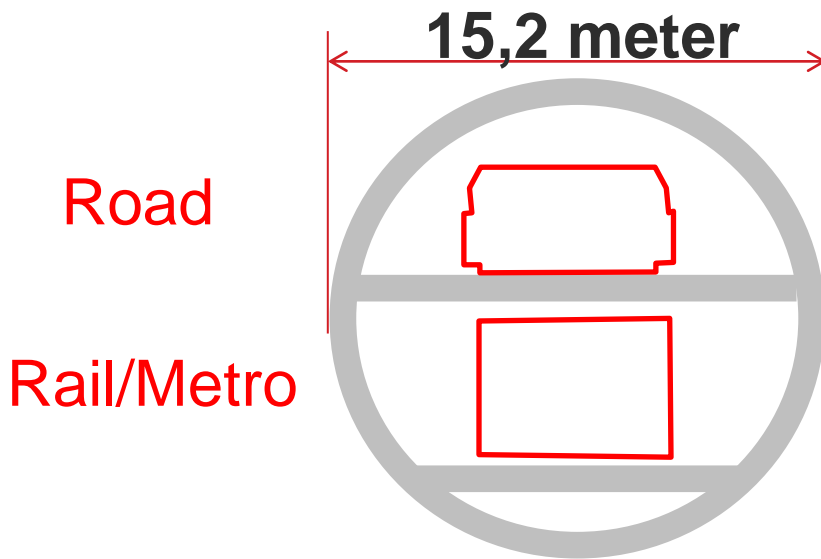
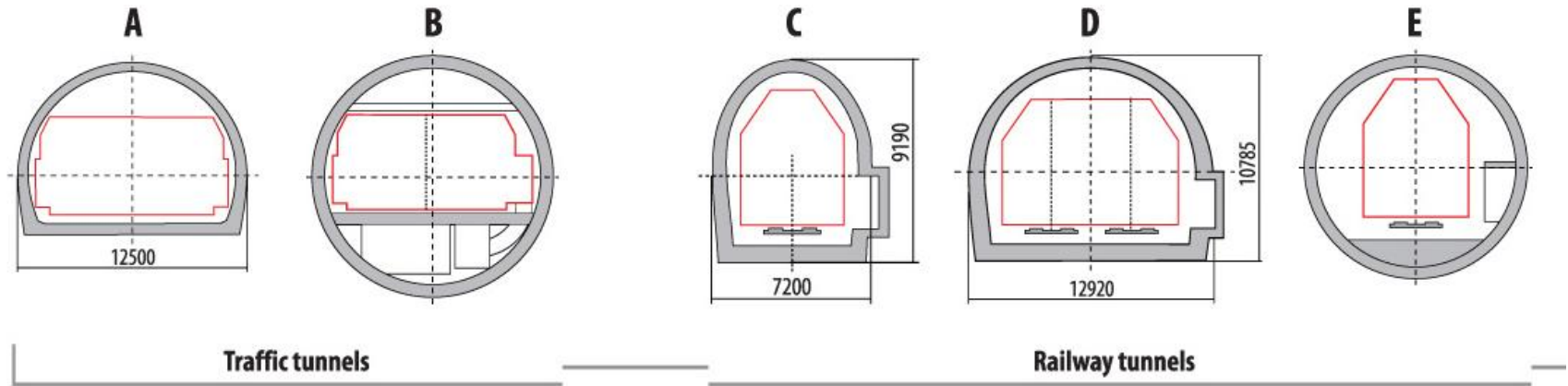

Duplex tunnel road only

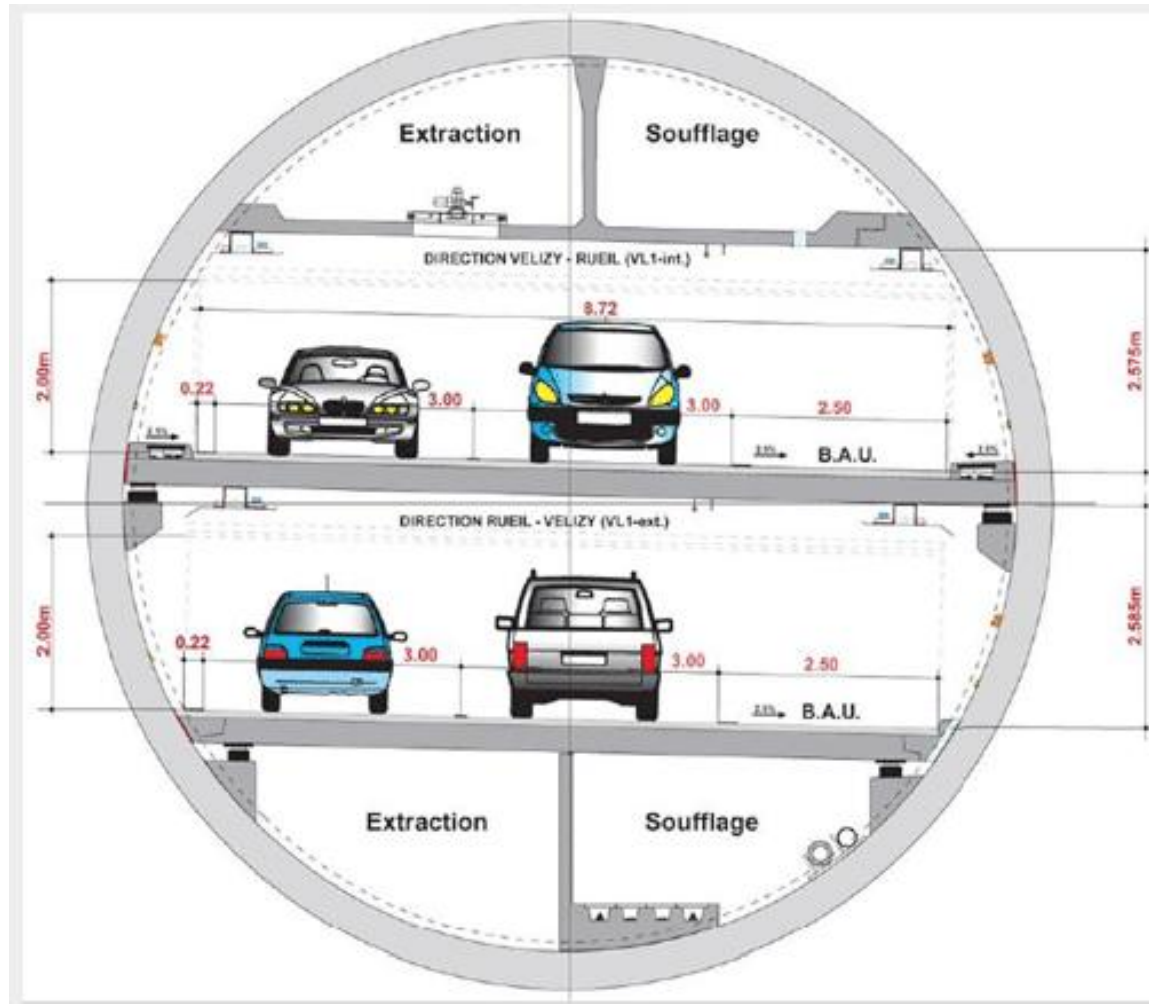

Duplex tunnel road/rail

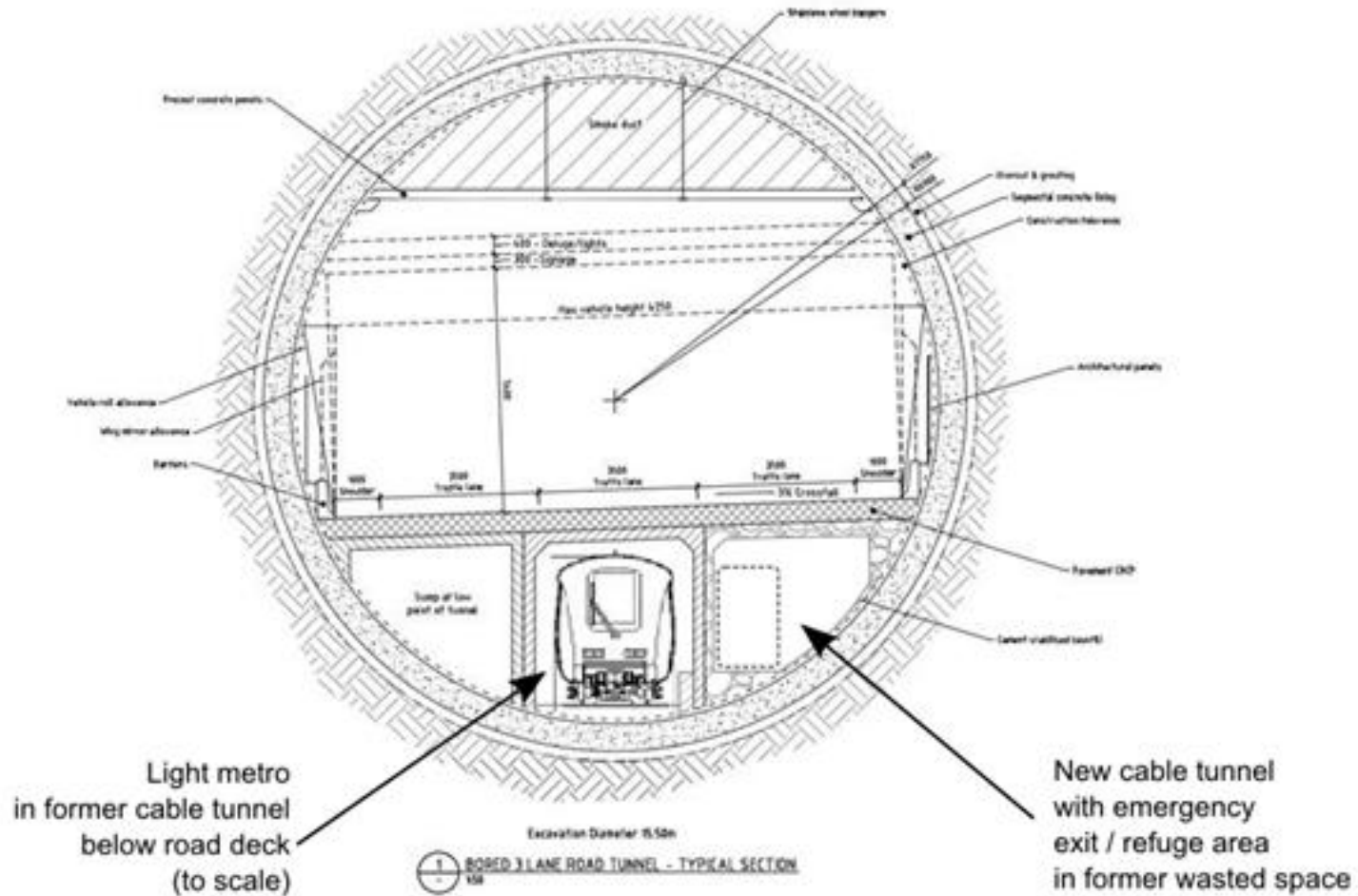

Duplex tunnel rail only

Metro Barcelona – Line 9

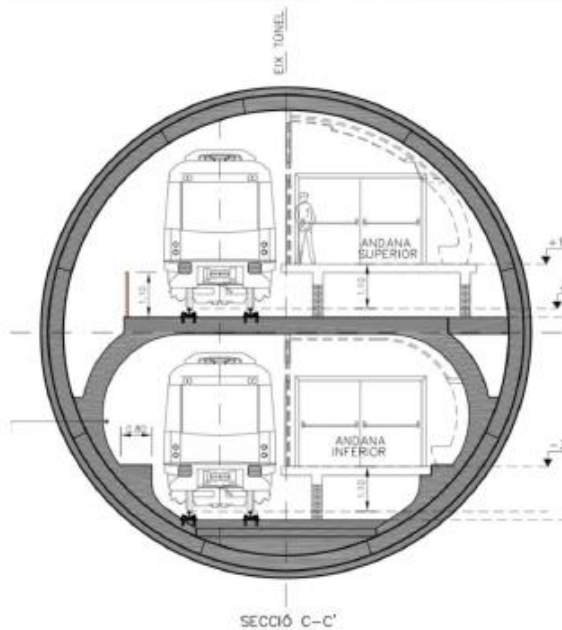

Cost effective duplex tunnels and bridges

| Tunnel type | Capacity Road | Capacity Rail | Tunnel Area m ² |
|------------------------|---------------|---------------|----------------------------|
| Single pipe | 1800 | 12000 | 38.5 – 78.5 |
| Double pipe | 3600 | 24000 | 77.0 - 157.0 |
| Single wide body pipe | 3600 | 24000 | 78.5 – 113.0 |
| Duplex rail/road | 7200 | 24000 | 176.6 |
| Duplex road only | 10800 | - | 88.2 |
| Duplex rail/metro only | - | 48000 | 176.6 |

Cost effective duplex tunnels and bridges

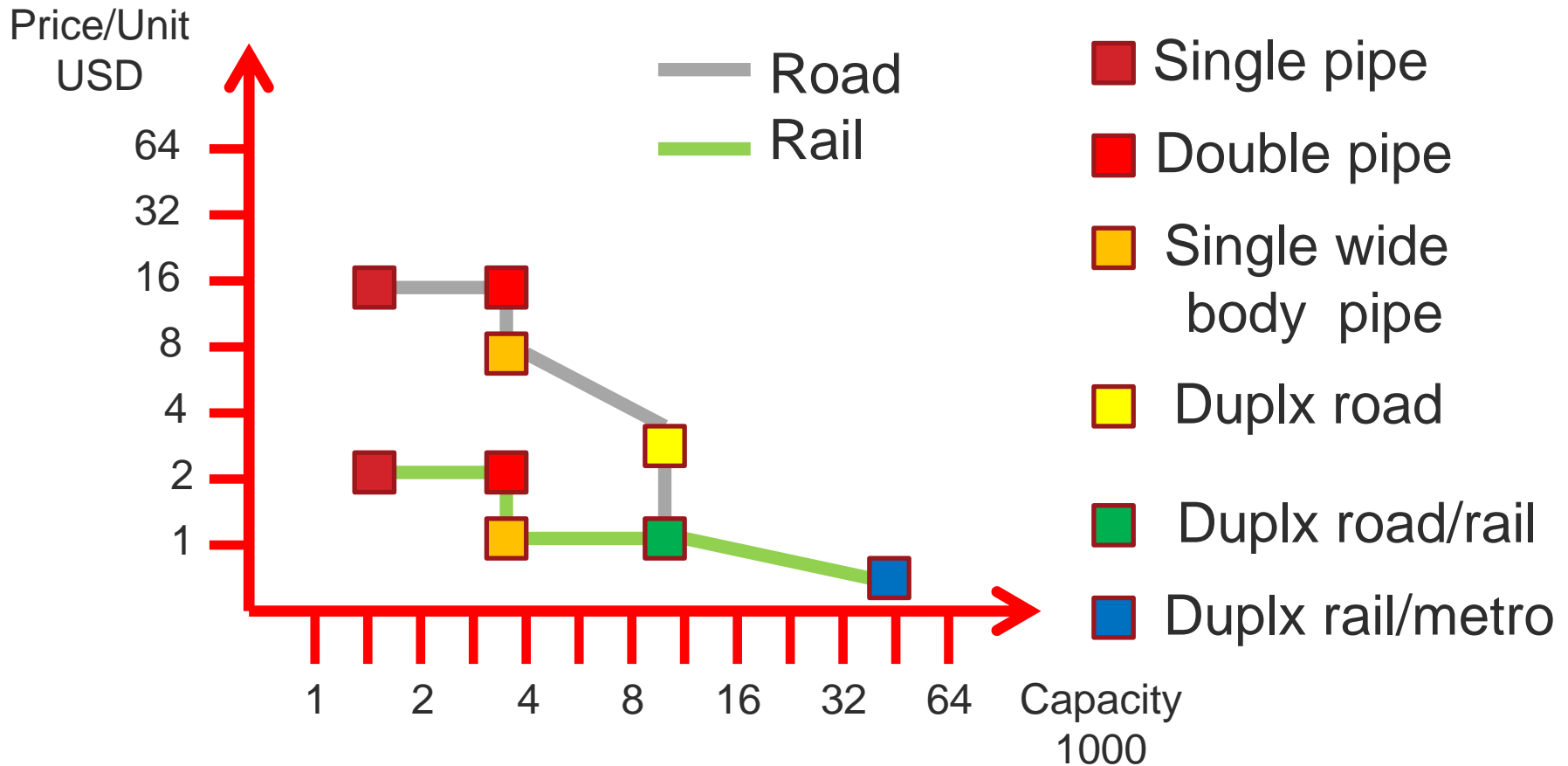

Conclusion

■ Double pipe tunnel

- Is the most costly alternative
- It is double the price of a single pipe wide body tunnel and the same price as a duplex tunnel but with half the capacity

■ Single pipe wide body tunnel

- Is the most cost effective tunnel for high speed lines

■ Duplex tunnel and bridges

- Is the most effective transport tunnel in urban areas
 - It promote new urban development and decreases traffic jams

**Develop the urban areas with duplex tunnels !
It gives high speed lines ultimate access to the city.**



PHILADELPHIA 2012
HIGHSPEED
8th World Congress on High Speed Rail

...Thank you
for your kind attention